



Further to constructive technical exchanges with ocean racers, Facnor has developed a new sophisticated range of Gennaker/Code Zero furlers : the FX+. A true evolution: light, easy to fit and aesthetic. Fitted on request with a ratchet device securing the furling, locking both clockwise and anti-clockwise (Facnor patent).

TECHNOLOGY OF THE FX+ FURLERS

The FX+ flying sails furler is an "in/out system". The anti-twist rope is captive within the sail luff tape.

FX+ Flying sails furler features:

- Widely tested & strong mechanisms bodies
- Lightness : optimised system and ultracompact (thanks to the carbon housing)
- Secured sail connection
- Easy to fit and to adjust & simplified use
- Conversion for asymmetrical spinnaker (p.34)
- Ratchet system

FX+
design by Facnor

Thimbles

- Stainless steel (FX+1500/2500/4500)
- aluminium (FX+7000/12000/20000). see p.38

Drum

- large diameter (torque ↗) : for a better furling power
- Drum and swivel, machined from one single piece

Torque Rope

More anti-twist is the rope, faster is the revolution (supplied on request).



Start and Go Rotation option

drum self-locking device (optional). Fitted with a ratchet (S/s Duplex)

Ratchet system



See the video on **YouTube**

Carbon housing

- lighter
- insures a smooth and perfect run of the furling line (no overriding)

Bottom and top adjustable fastenings (see page 38)

Various attachment

(option 2-to-1 see page 38)

Anti-impact cover for swivel

in neoprene (delivered) high-visibility marking



Secured sail connection Sail / Mechanism



Smooth push spring release device*

*except for FX+900)

+ Captive quick release pin



Easy fitted furling line



Stainless steel guide

Furling line





FXT FURLERS WITH DRUM

FXT Gennaker and Code Zero furler

- quickly installed and removed after use.
- The FXT is fitted with steel bearings protected by waterproof joints (maintenance free)
- good technical and economical alternative solution for users who prefer a discontinuous furling line.

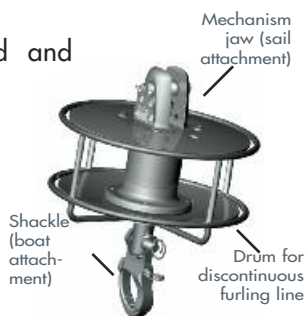

The main criteria (but not exhaustive) to select the model Gennaker and Code Zero furler model is the loads of the sail (see below) :

FXT Model	FXT 4500	FXT 7000	FXT CUSTOM
Boat length (meters-feet)	9,5 → 16 m	+ 16 m	on request
	31' → 55'	+ 55'	
Max. sail area (meters ² - feet ²)	100 m ²	200 m ²	
	1073 ft ²	2147 ft ²	
Safe Working Load* (tons- lbs)	4,5 T	7 T	
	9920 lbs	15432 lbs	

* SWL maxi : see note at bottom of page

- The swivel and the drum are fitted with the same bearings (top shackle for halyard fitting).

The Gennaker continuous line furler

FX+ are made of one swivel and one flat continuous line drum (maximum luff and no overlapping round the drum).

- carbon house
- half the weight of a standard Gennaker furler.



FX+ CONTINUOUS LINE FURLERS

The wide FX range from 16' day boat to 100' mega yachts :

FX+ Model	FX+ 900	FX+ 1500	FX+ 2500	FX+ 4500	FX+ 7000	FX+ 12000	FX+ 20000
Boat length (meters-feet)	6 ↓ 10,5	10 ↓ 12	12 ↓ 14	13 ↓ 16	16 ↓ 20	+20 ↓	+25 ↓
	20 ↓ 30	30 ↓ 40	40 ↓ 45	42 ↓ 55	55 ↓ 70	+70	+82
Max Gennaker or Code zero area (m ² ft ²)	30 m ²	60 m ²	100 m ²	140 m ²	250 m ²	350 m ²	+ 500 m ²
	322 ft ²	646 ft ²	1076 ft ²	1500 ft ²	2690 ft ²	3770 ft ²	5380 ft ²
Safe Working Load* (tons- lbs)	0,9T	1,5T	2,5T	4,5T	7T	12T	20T
	1984 lbs	3306 lbs	5511 lbs	9920 lbs	15432 lbs	26455 lbs	44100 lbs
Ratchet	Not available	Not available	Option	Option	Option	Contact us	

* SWL maxi : see note at bottom of page

- Leading in Gennaker furler manufacturing Facnor has acquired a long experience on these types of products - tested during ocean races in extremely tough conditions.

> **New!**

- **Ratchet system** : Option for FX+2500, 4500 & 7000 (retrofit available on most FX+ models)



See the video on :



STAYSAIL FITTED ON FX+ FURLERS

Staysail on a FX+ furler :



a Staysail can be fitted on a FX+ furler so that a storm-sail can be used according to the weather conditions. In this configuration, we recommend to install a 2-to-1 block (halyard better tighten and less tension in the mast).

FX+ Model	FX+ 1500	FX+ 2500	FX+ 4500	FX+ 7000	Structural furler
Staysail max area indicatives datas (m ² ft ²)	20 m ²	30 m ²	50 m ²	70 m ²	over 70' boat, it is highly recommended to fit a structural furler (see page 24)
	215 ft ²	322 ft ²	538 ft ²	753 ft ²	
Safe Working Load* (tons)	1,5 T	2,5 T	4,5 T	7 T	
	3306 lbs	5511 lbs	9920 lbs	15432 lbs	



We remind you that an adapted deck attachment must be installed

- FX+ for staysails : ideally featted with a locking swivel (see P. 27)

* The S.W.L. is the maximum safe working load over which distortions of the furler can appear. This load is approx. 50% of the breaking load (depending on models)

2-to-1 block option :

see options P. 38

USE CONDITIONS OF THE FXT or FX FURLER

Use conditions

The use range of the sails as shown on the diagram opposite varies with the force of the wind. The complementary use with closer reach headsails is possible, however, under certain conditions. (see page 31).

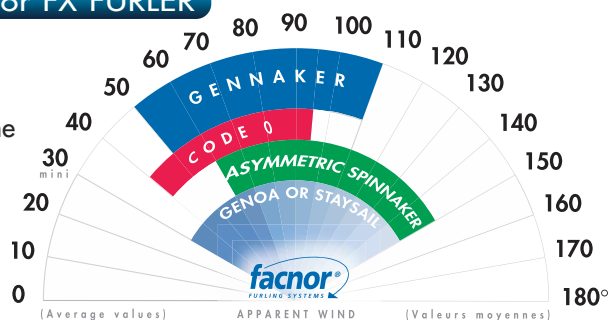

Sail indicative range of use
This sail indicative range of use varies with the wind force

Installation of the FX+ furler (Gennaker or Code zero) :

The short sequence below shows how easily the Gennaker furler is installed :

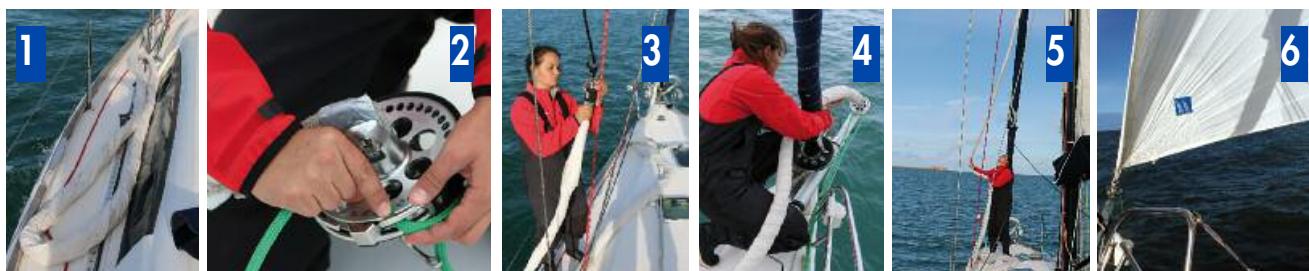

- Lay the furled Gennaker on the deck (fig. 1). Install the furling line round the drum (fig. 2). See below for details;
 - Fasten the upper thimble onto the swivel protected by the a neoprene cover, supplied in the kit (fig.3). Attach the drum onto the chain plate or bowsprit (fig. 4). Adjust the bowsprit and secure with a bridle
 - Check that the halyard is clear, hoist the sail (fig 5), tighten and control the sail sheet (fig 6). Ready!
 - Ratchet system : From a locked position, release the ratchet by operating the drum by rotating (furling in) half a turn. Once released the sail will unfurl easily
- Note: always keep the reefing line under tension and fit a line stopper. Lower the furled sail after use.

FURLING LINE AND QUICK FASTENING DEVICES

Installation of the furling line : through one guide exit fit the line into the round and smooth notch situated on the drum edge. Then, simply turn the drum and the line up to the opposite guide exit. Easy to deinstall.

Easy installed and stored :

- top and bottom adjustable fastenings : snapshakle or shackle.
- adapted systems for asymmetric Spinnakers and attachments see page 34.



Fitted-in and secure sail connection :

- The sail can be removed from the furler in one "click".
- Smooth push spring release device* with captive quick release pin for FX+ models, except FX+900 secured with clevis pin.

Used for different sails :

As it is very simple to disconnect the sail from the furler and to fit a 2-to-1 block on the swivel, the Gennaker can be quickly changed for the staysail if needed*.

* provided that the loads are equivalent for both sails (see pages 31). Your Facnor agent will advise you on the best possible solution.

REMOVABLE FURLING LINE

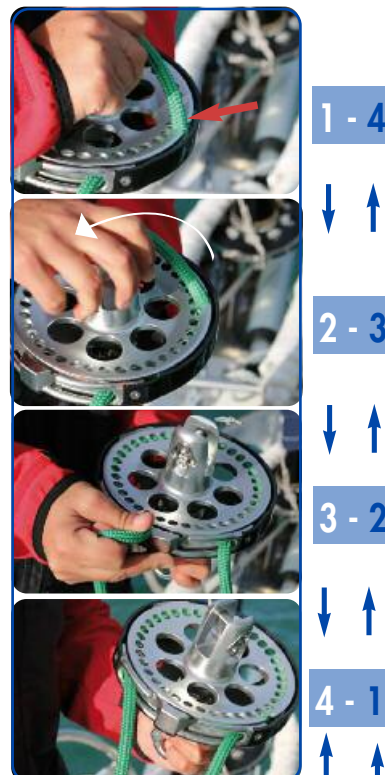



Furling with the ratchet system :

Lay Furling OUT with the ratchet option on.

From a locked position, rotate the drum half a turn (furling in) to release the ratchet lock. Once released the sail will unfurl easily. Furling IN with the ratchet option on.

Start furling in. If you stop at any time and let go of the furling line, the flying sail will be automatically locked, thanks to the ratchet device. Once ready to resume, simply start furling again. The ratchet in the continuous line drum will be automatically activated from the first rotation.



FX+ DIMENSIONS

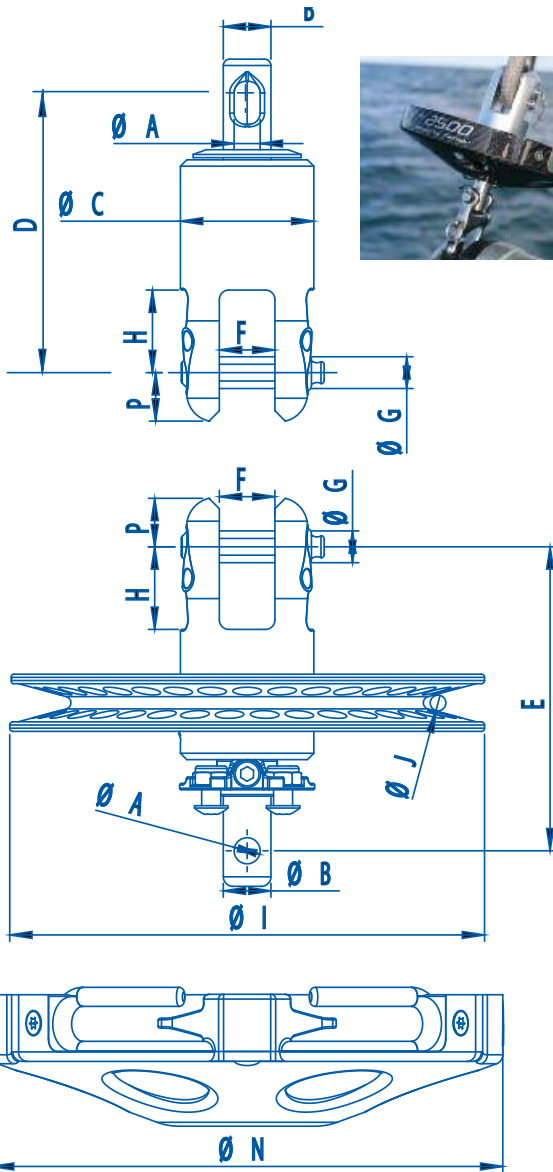

Measurements (mm)	FX+ 900	FX+ 1500	FX+ 2500	FX+ 4500	FX+ 7000	FX+ 12000 Std	FX+ 12000 Racing	FX+ 20000
	Dimensions (mm)							
ø A	6	6	8	10	12	16		20
ø B	12	12	15	20	25	30		40
ø C	31	34	42	49,5	60	72		86
D	61	66	88	100	113	125		153
E	74	83	96	110	125	134		161
F	12	15	17,5	19	26	26	22	29
ø G	8	8	10	12	14	16	18	20
H	18	22	26	33,2	39	43	39	50
I	85	109	149	169	199	248		298
J	6	8	8	10	10	12		12
L	40,5	40,5	62	65,5	88,5	-	-	-
M	35	35	41	52,5	61	78		90
ø N	95	121,5	161	181,5	212	272		332
P	10,8	11,7	15,3	18,5	19,9	25		28

Standard drum attachment (snap shackle)
Standard swivel attachment (shackle)

Swivel weight (g)	123	153	304	498	709	1320	2540
Drum weight (g)	290	382	709	1026	1459	3040	5140

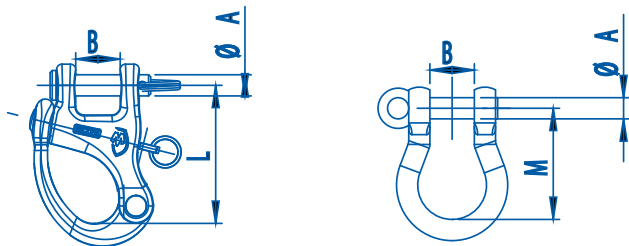

Important : NEVER SAIL WITH THE GENNAKER OR CODE ZERO PARTIALLY FURLED. ONCE FURLED, NEVER RELY ON THE RATCHET TO FULLY SECURE YOUR SAIL

© Joka Gemesil / Pauger

