

Booms with a strong profile

Seldén booms have a wealth of sophisticated features and can be equipped with a variety of reefing systems to suit different boats and the needs of different sailors. The booms can be fitted for traditional slab reefing or Single Line Reef, or be used for furling masts. The boom extrusions are relatively deep in relation to their width, allowing a lighter extrusion with high resistance to vertical bending. This makes them perfect for use with modern, stiff sailcloth and efficient Rodkicker rigid vang.

Inboard end

The inboard end fitting contains sheaves for reef lines and outhaul. Spring loaded rope stoppers can be fitted to the inboard end as option. Every stopper is colour-coded to match the relevant line. The clevis pin connecting the inboard end to the boom toggle has a D-shaped head in order to prevent rotation.

A perfect end

The boom end is gently rounded. It is fastened with screws and is open at the back to facilitate maintenance and line replacement. It comes with a cast preventer bracket, a topping lift eye and numbered line compartments.

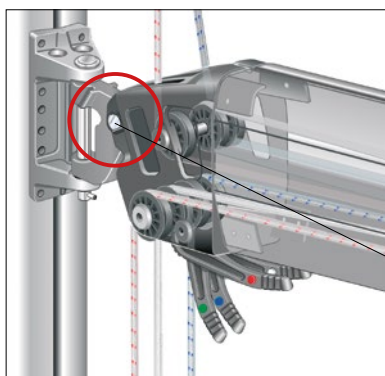

D-shaped head of clevis pin.
See spare parts list for details.

	Boom section	Dim., mm height/widht	I_y cm ⁴	I_x cm ⁴	Wall thickness mm	Weight kg/m	W_y min cm ³	W_x min cm ³	Sail groove mm
	B087	86/60	60.2	27.7	2.0	1.55	13.4	9.3	5.5 ± 0.6
	B104	104/60	97.5	33.6	2.0	1.71	18.5	11.2	5.5 ± 0.6
	B120	120/62	155	42.5	1.8	2.12	24.8	13.7	5.5 ± 0.75
	B135	135/71	265	70	2.0-2.8	2.66	39	19.5	5.8 ± 0.75
	B153	153/86	438	132	2.5-2.9	3.60	55.2	30.8	10 ± 0.75
	B172	171/98	720	219	2.3-3.2	4.66	81.5	44.7	10 ± 0.75
	B199	199/122	1257	407	3.1	5.90	124.6	67.00	10 ± 0.75
	B250	250/140	2706	692	3.2	7.95	200.1	101.3	6.25 ± 0.75
	B290	290/155	5209	1524	4.1	11.50	339	196	10.25 ± 0.75
	B380	380/186	12030	3283	4.5-9.0	17.80	586	353	No groove

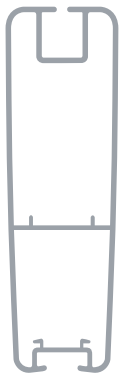

Seldén racing booms

Developed jointly with sailors and designers in the World Match Racing Tour. Deep boom profile for maximum vertical stiffness. This retains sail trim, even at very high kicker and sheet loads.

	Boom section	Dim., mm height/width	I_y cm ⁴	I_x cm ⁴	Wall thickness mm	Weight kg/m	$W_{y^{min}}$ cm ³	$W_{x^{min}}$ cm ³	Sail groove mm
	B190	190/60	723	94	2.5-3.5	4.86	74	31	5.5±0.75
	B230	230/70	1399	176	2.7-3.6	6.53	117.8	50.5	6.25±0.75

Reefing systems

Traditional slab reef

This is a simple and efficient reefing system. The reef cringle on the luff is hooked on to fixed hooks at the inboard end. The leech is reefed down with a line running to a winch at the mast. Stoppers at the inboard end allow the same winch to be used with any line on the boom. Lines not in use are kept clear of the winch by a lineguide. Alternatively, the line can lead aft to a cockpit winch.

The boom can also be equipped for slab reefing with hooks on lines. This system is suitable for larger yachts where it can be difficult to hook the reef cringle to a fixed hook in heavy winds.

S-Hooks for slab reef or Cunningham

Art. No.	Diameter, mm	Ultimate load, N
307-407	6	5000
307-408	8	6500
307-410	10	9500

Instant reefing with Single Line Reef

Single Line Reef is a familiar concept, but made practical and reliable by Seldén. All you do is ease off the halyard to premarked reefing points and then haul in on the reefing line. The luff and the leech are reefed at the same time. A system of guided blocks inside the boom ensures that the lines do not tangle. The system has a 2:1 gear ratio, making reefing fast and simple, without having to leave the cockpit.

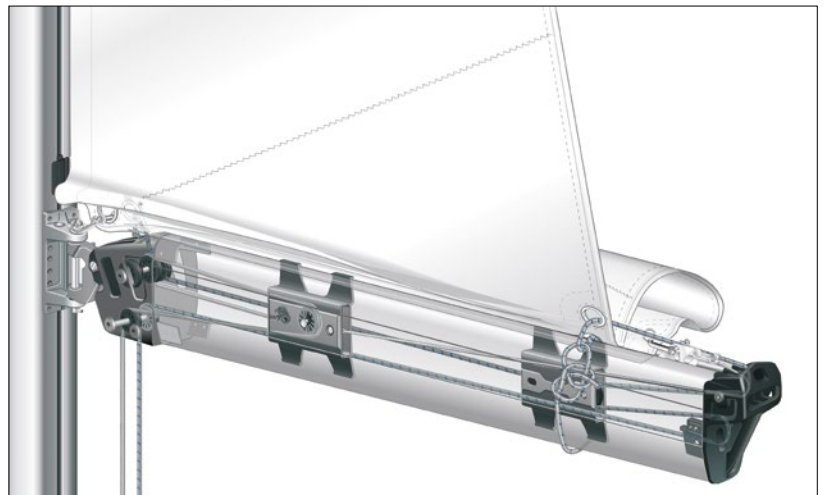

Single Line Reef. Pulls down luff and leech at the same time. Operated from the safety of the cockpit.

Seldén furling mast

When used with a furling mast, the booms are fitted with low friction outhaul cars. The cars are equipped with horizontal and vertical wheels, enabling them to absorb forces from every direction.



Boom fitted with outhaul car for Seldén furling mast.

Single Line Reef



Release the Rodkicker.



Slacken the mainsheet.



Ease off the main halyard to premarked reefing points.



Tension the reef line up to the marked position on the line.



*The reef is in.
Remove any slack in other reefs.*

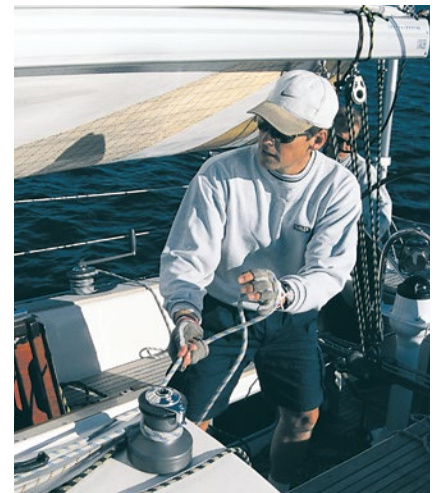

If necessary, apply more main halyard tension.



Adjust the mainsheet.



Adjust the Rodkicker.



It's as simple as that!

Boom sections choice

To select the correct boom section, you will need to know the sail foot length (E) and righting moment (RM). If the RM is not known, displacement is an alternative.

The E and Y measurements must also be known for dimensioning purposes. The length of the boom is sometimes determined by other factors than E and therefore we need the S measurement as well. A good example is when the boom extrusion needs an over-length to allow the main sheet to pass a sprayhood.

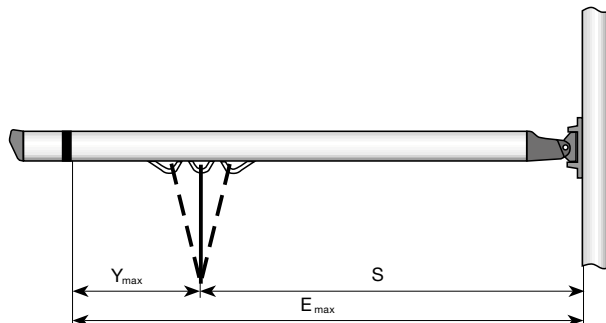

Masthead rigs, E_{max} and Y_{max} (m)

Section	RM 30 kNm	Displ. tonnes	B087		B104		B120		B135		B153		B172		B199		B250		B290		B380		
			E_{max}	Y_{max}	E_{max}	Y_{max}	E_{max}	Y_{max}	E_{max}	Y_{max}	E_{max}	Y_{max}	E_{max}	Y_{max}	E_{max}	Y_{max}	E_{max}	Y_{max}	E_{max}	Y_{max}	E_{max}	Y_{max}	
6	1.2		3.3	1.7	4.0	1.8	4.2	2.1															
8	1.6		3.3	1.4	4.0	1.6	4.2	1.8	4.6	2.5													
10	2.0		3.3	1.3	4.0	1.4	4.2	1.6	4.6	2.2													
12	2.4		2.9	1.2	4.0	1.3	4.2	1.5	4.6	2.0	5.1	3.1											
14	2.8		2.6	1.1	3.5	1.2	4.2	1.4	4.6	1.9	5.1	2.8											
16	3.2				3.2	1.1	4.2	1.3	4.6	1.8	5.1	2.7	6.1	3.7									
18	3.6				3.0	1.1	4.1	1.2	4.6	1.7	5.1	2.5	6.1	3.5									
20	4.0				2.8	1.0	3.8	1.1	4.6	1.6	5.1	2.4	6.1	3.3									
25	5.0				2.4	0.9	3.3	1.0	4.6	1.4	5.1	2.1	6.1	2.9									
30	5.7						2.9	0.9	4.5	1.3	5.1	1.9	6.1	2.7	6.6	4.1							
35	6.3						2.6	0.9	4.0	1.2	5.1	1.8	6.1	2.5	6.6	3.8							
40	7.0								3.7	1.1	5.1	1.7	6.1	2.3	6.6	3.5							
45	7.7								3.4	1.1	4.8	1.56	6.1	2.2	6.6	3.3							
50	8.2								3.2	1.0	4.5	1.5	6.1	2.1	6.6	3.2							
55	9.0										4.2	1.4	6.1	2.0	6.6	3.0							
60	10										3.9	1.4	5.8	1.9	6.6	2.9							
70	11										3.5	1.3	5.2	1.8	6.6	2.7	7.6	3.7					
80	12										3.2	1.2	4.7	1.6	6.6	2.5	7.6	3.5					
90	14										3.0	1.1	4.4	1.5	6.6	2.4	7.6	3.3					
100	15										2.7	1.1	4.1	1.5	6.2	2.2	7.6	3.1					
110	16												3.8	1.4	5.8	2.1	7.6	3.0					
120	18												3.6	1.3	5.5	2.0	7.6	2.8					
130	19												3.4	1.3	5.2	2.0	7.6	2.7	8.5	4.3			
140	20												3.2	1.2	4.9	1.9	7.6	2.6	8.5	4.1			
150	22														4.7	1.8	7.5	2.5	8.5	4.0			
160	23														4.5	1.8	7.2	2.5	8.5	3.8			
170	25														4.3	1.7	6.9	2.4	8.5	3.7	12	6.1	
180	26														4.1	1.7	6.6	2.3	8.5	3.6	12	5.9	
190	27														4.0	1.6	6.4	2.3	8.5	3.5	12	5.8	
200	28														3.8	1.6	6.1	2.2	8.5	3.4	12	5.6	
220	31																5.7	2.1	8.5	3.3	12	5.4	
240	34																5.4	2.0	8.5	3.1	12	5.1	
260																			8.5	3.0	12	4.9	
280																			8.2	2.9	12	4.7	
300																			7.9	2.8	12	4.6	
320																					12	4.4	
340																					12	4.3	
360																					12	4.2	
380																						11.6	4.1
400																						11.2	4.0



Fractional rigs, E_{max} and Y_{max} (m)

Section	RM 30 kNm	Displ. tonnes	B087		B104		B120		B135		B153		B172		B199		B250		B290		B380	
			E_{max}	Y_{max}	E_{max}	Y_{max}	E_{max}	Y_{max}	E_{max}	Y_{max}	E_{max}	Y_{max}	E_{max}	Y_{max}	E_{max}	Y_{max}	E_{max}	Y_{max}	E_{max}	Y_{max}	E_{max}	Y_{max}
6	1.2		3.4	1.4	4.1	1.6	4.1	1.8														
8	1.6		3.3	1.2	4.1	1.4	4.1	1.6	4.6	2.1												
10	2.0		2.8	1.1	3.7	1.2	4.1	1.4	4.6	1.9												
12	2.4		2.5	1.0	3.3	1.1	4.1	1.3	4.6	1.8												
14	2.8		2.2	0.9	3.0	1.0	4.1	1.2	4.6	1.6	5.1	2.5										
16	3.2		2.0	0.9			2.7	1.0	3.7	1.1	4.6	1.5	5.1	2.3								
18	3.6				2.5	0.9	3.4	1.0	4.6	1.4	5.1	2.2	6.1	3.0								
20	4.0						3.2	1.0	4.6	1.4	5.1	2.1	6.1	2.8								
25	5.0						2.7	0.9	4.3	1.2	5.1	1.8	6.1	2.5	6.6	3.8						
30	5.7								3.8	1.1	5.1	1.7	6.1	2.3	6.6	3.5						
35	6.3								3.4	1.0	4.8	1.6	6.1	2.1	6.6	3.2						
40	7.0								3.1	1.0	4.3	1.4	6.1	2.0	6.6	3.0						
45	7.7										4.0	1.4	5.9	1.9	6.6	2.9						
50	8.2										3.7	1.3	5.5	1.8	6.6	2.7						
55	9.0										3.5	1.2	5.1	1.7	6.6	2.6	7.6	3.6				
60	10										3.3	1.2	4.8	1.6	6.6	2.5	7.6	3.5				
70	11										2.9	1.1	4.3	1.5	6.6	2.3	7.6	3.2				
80	12												4.0	1.4	6.0	2.1	7.6	3.0				
90	14												3.6	1.3	5.6	2.0	7.6	2.8				
100	15												3.4	1.3	5.2	1.9	7.6	2.7				
110	16												3.2	1.2	4.8	1.8	7.6	2.6				
120	18														4.5	1.8	7.3	2.4				
130	19														4.3	1.7	6.9	2.3	8.5	3.7		
140	20														4.1	1.6	6.6	2.3	8.5	3.5		
150	22														3.9	1.6	6.2	2.2	8.5	3.4		
160	23														3.7	1.5	6.0	2.1	8.5	3.3		
170	25														3.6	1.5	5.7	2.1	8.5	3.2	12.0	5.2
180	26														3.4	1.4	5.5	2.0	8.5	3.1	12.0	5.1
190	27														3.3	1.4	5.3	1.9	8.5	3.0	12.0	5.0
200	28																5.1	1.9	8.5	3.0	12.0	4.8
220	31																4.8	1.8	8.1	2.8	12.0	4.6
240	34																4.5	1.7	7.6	2.7	12.0	4.4
260																			7.2	2.6	12.0	4.2
280																			6.8	2.5	11.9	4.1
300																			6.5	2.4	11.4	3.9
320																					10.9	3.8
340																					10.4	3.7
360																					10.0	3.6
380																					9.6	3.5
400																					9.3	3.4

Booms for slab reef, Single Line Reef and furling masts

After you have determined the correct boom section for your yacht (previous tables), all you have to do is decide what kind of reefing system you prefer. Then check the tables below to find the complete boom in question. If you are in any doubt about which boom to choose, please contact your Seldén dealer for expert advice. When fitting a Seldén boom to a mast of another brand, check the existing toggle's dimensions for compatibility.

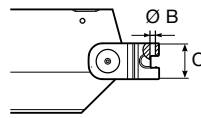

* Boom connects directly to gooseneck bracket. (B190 and B230)

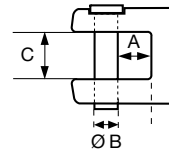

B087-B290

Booms for furling masts

Art. No.	Boom section	E _{max} mm
BS 120-72B	B120	3505
BS 120-73B		4005
BS 135-72	B135	4055
BS 135-73		4555
BS 153-72	B153	4520
BS 153-73		5020
BS 153-74		5520
BS 172-71	B172	4530
BS 172-72		5030
BS 172-73		5530
BS 172-74		6130
BS 199-71	B199	5530
BS 199-72		6630
BS 250-71B	B250	5610
BS 250-72B		6110
BS 250-73B		7110
BS 250-74B		7510
BS 290-71	B290	6885
BS 290-73		8385

Inboard end

Boom section	A mm	B mm	C mm
B087	8	8	16
B104	8	8	16
B120	14	10	20
B135	14	12	20
B153	13	12	21
B172	16	12	20
B199	21	16	30
B250	18	16	30
B290	30	16	30
B190*	-	12.2	78
B230*	-	12.2	78





Slab reef and Single Line Reef booms

Art. No.	Boom section	E _{max} mm	Remarks
BS 087-01	B087	3365	Outhaul (2:1) + 2 reefs, aft
BS 087-21		3365	Outhaul (4:1) + 2 reefs, cam cleats
BS 087-61		3365	Outhaul (2:1) + 2 Single Line Reef, aft
BS 104-01	B104	3515	Outhaul (2:1) + 2 reefs, aft
BS 104-02		4015	Outhaul (2:1) + 2 reefs, aft
BS 104-21		3515	Outhaul (4:1) + 2 reefs, cam cleats
BS 104-22		4015	Outhaul (4:1) + 2 reefs, cam cleats
BS 104-61		3515	Outhaul (2:1) + 2 Single Line Reef, aft
BS 104-62		4015	Outhaul (2:1) + 2 Single Line Reef, aft
BS 120-03B	B120	4040	Outhaul (3:1) + 2 reefs, aft
BS 120-23		4135	Outhaul (3:1) + 2 reefs, jam levers
BS 120-63B		4040	Outhaul (3:1) + 2 Single Line Reef, aft
BS 135-02	B135	4105	Outhaul (3:1) + 2 reefs, aft
BS 135-03		4605	Outhaul (3:1) + 2 reefs, aft
BS 135-22		4105	Outhaul (3:1) + 2 reefs, jam levers
BS 135-23		4605	Outhaul (3:1) + 2 reefs, jam levers
BS 135-62		4105	Outhaul (3:1) + 2 Single Line Reef, aft
BS 135-63		4605	Outhaul (3:1) + 2 Single Line Reef, aft
BS 153-02	B153	4570	Outhaul (3:1) + 3 reefs, aft
BS 153-03		5070	Outhaul (3:1) + 3 reefs, aft
BS 153-04		5570	Outhaul (3:1) + 3 reefs, aft
BS 153-22		4570	Outhaul (3:1) + 2 reefs, jam levers
BS 153-23		5070	Outhaul (3:1) + 2 reefs, jam levers
BS 153-24		5570	Outhaul (3:1) + 2 reefs, jam levers
BS 153-62		4570	Outhaul (3:1) + 2 Single Line Reef, aft
BS 153-63		5070	Outhaul (3:1) + 2 Single Line Reef, aft
BS 153-64		5570	Outhaul (3:1) + 2 Single Line Reef, aft
BS 172-01	B172	4580	Outhaul (3:1) + 3 reefs, aft
BS 172-02		5080	Outhaul (3:1) + 3 reefs, aft
BS 172-03		5580	Outhaul (3:1) + 3 reefs, aft
BS 172-04		6180	Outhaul (3:1) + 3 reefs, aft
BS 172-21		4580	Outhaul (3:1) + 3 reefs, jam levers
BS 172-22		5080	Outhaul (3:1) + 3 reefs, jam levers
BS 172-23		5580	Outhaul (3:1) + 3 reefs, jam levers
BS 172-24		6180	Outhaul (3:1) + 3 reefs, jam levers



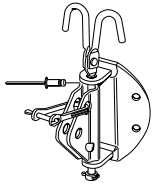

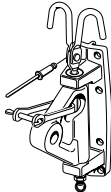
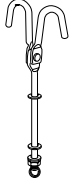
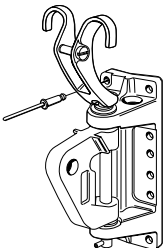
Aft = Lines to cockpit. Jam levers/cam cleats = Lines operated at gooseneck.

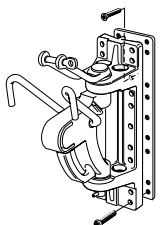
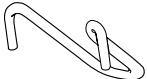
Art. No.	Boom section	E _{max} mm	Remarks
BS 172-61	B172	4580	Outhaul (3:1) + 2 Single Line Reef, aft
BS 172-62		5080	Outhaul (3:1) + 2 Single Line Reef, aft
BS 172-63		5580	Outhaul (3:1) + 2 Single Line Reef, aft
BS 172-64		6180	Outhaul (3:1) + 2 Single Line Reef, aft
BS 190-02	B190	4940	Outhaul + 2 reefs, aft
BS 190-03		5440	Outhaul + 2 reefs, aft
BS 190-62		4940	Outhaul + 2 Single Line Reef, aft
BS 190-63		5440	Outhaul + 2 Single Line Reef, aft
BS 199-01	B199	5590	Outhaul (4:1) + 3 reefs, aft
BS 199-02		6690	Outhaul (4:1) + 3 reefs, aft
BS 199-21		5590	Outhaul (4:1) + 3 reefs, jam levers
BS 199-22		6690	Outhaul (4:1) + 3 reefs, jam levers
BS 199-61		5590	Outhaul (4:1) + 2 Single Line Reef, aft
BS 199-62		6690	Outhaul (4:1) + 2 Single Line Reef, aft
BS 230-01	B230	4540	Outhaul + 2 reefs, aft
BS 230-02		4940	Outhaul + 2 reefs, aft
BS 230-03		5440	Outhaul + 2 reefs, aft
BS 230-04		6040	Outhaul + 2 reefs, aft
BS 230-61		4540	Outhaul + 2 Single Line Reef, aft
BS 230-62		4950	Outhaul + 2 Single Line Reef, aft
BS 230-63		5440	Outhaul + 2 Single Line Reef, aft
BS 230-64		6040	Outhaul + 2 Single Line Reef, aft
BS 250-01B	B250	5670	Outhaul (4:1) + 3 reefs, aft
BS 250-02B		6170	Outhaul (4:1) + 3 reefs, aft
BS 250-03B		7170	Outhaul (4:1) + 3 reefs, aft
BS 250-04B		7570	Outhaul (4:1) + 3 reefs, aft
BS 250-21B		5670	Outhaul (4:1) + 3 reefs, jam levers
BS 250-22B		6170	Outhaul (4:1) + 3 reefs, jam levers
BS 250-23B		7170	Outhaul (4:1) + 3 reefs, jam levers
BS 250-24B		7570	Outhaul (4:1) + 3 reefs, jam levers
BS 250-61B		5670	Outhaul (4:1) + 2 Single Line Reef, aft
BS 250-62B		6170	Outhaul (4:1) + 2 Single Line Reef, aft
BS 250-63B		7170	Outhaul (4:1) + 2 Single Line Reef, aft
BS 250-64B		7570	Outhaul (4:1) + 2 Single Line Reef, aft
BS 290-01	B290	6885	Outhaul + 2 reefs, aft
BS 290-03		8385	Outhaul + 2 reefs, aft
BS 290-61		6885	Outhaul (3:1) + 2 Single Line Reef, aft
BS 290-63		8385	Outhaul (3:1) + 2 Single Line Reef, aft

Boom brackets, E-sections, D-sections and R-sections

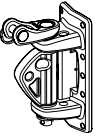
Fitting	Mast section	Boom bracket Art. No.	Boom type	Boom section	Dimension, mm	Fasteners Art. No.	Separate pin, hooks Art. No.
	For pear-shaped mast sections P100, P111	508-052-11 508-052-12	Single line reef (no hooks) Slab reef (with hooks)	B087 B104	Bracket Height: 80 Width: 63 Back angle: 45 Toggle Width: 13 Hole: Ø 8.2	4 pop rivets 167-004	Pin incl. reef hooks: 536-101-01 
		508-052-13 508-052-14	Single line reef (no hooks) Slab reef (with hooks)	B120	Toggle Width: 20 Hole: Ø 10		
	D109, D121 D129, D137 D146, D160 E122, E130 E138, E155 E170, E177, E189	508-040-07	Slab reef (with hooks)	B120	Bracket Height: 138 Width: 44 Back angle: 10° Toggle Width: 20 Hole: Ø 10.5	8 pop rivets 167-002	Pin incl. reef hooks: 536-102-01 
		508-040-01	Single line reef (no hooks)	111/75 128/90			
	E170, E177 E189, E206 E224, E237 E274	508-168-53 508-168-52	Slab reef (with hooks) Single line reef (no hooks)	143/76 B171 B172	Bracket Height: 179 Width: 63 Back angle: 10° Toggle Width: 20 Hole: Ø 12.5	12 pop rivets 167-002	Separate reef hooks: 536-113-01 Max. RM. Masthead 60 kNm Fractional 45 kNm 
		R190, R213 R235	508-168-21	Furling mast RA (no hooks)			
	E189, E206 E224, E237 E274	508-152-03	Slab reef (with hooks)	B199 B200	Bracket Height: 275 Width: 70 Back angle: 10° Toggle Width: 30 Hole: Ø 16.5	200/117 boom: 18 pop rivets 167-027	Separate reef hooks: 507-651 Max. RM. Masthead 120 kNm Fractional 90 kNm 
		508-152-23		B250		250/140 boom: 18 screws 155-803 + 2 screws 162-024 + backing plate	
		508-152-02	B199 B200	Single line reef (no hooks)			
		508-152-22	B250				

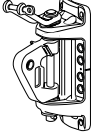

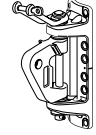
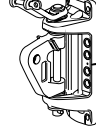
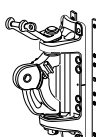
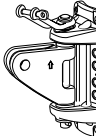
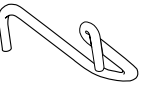
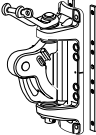
Boom brackets, C-sections and F-sections

Fitting	Mast section	Boom bracket Art. No.	Boom type	Boom section	Dimension, mm	Fasteners Art. No.	Separate pin, hooks Art. No.
	C137-C175	508-788-03	Single line reef (no hooks)	B087 B104	Bracket Height: 130 Width: 55 Toggle (AL) Width: 15 Hole: Ø 8	10 pop rivets 167-006	536-118
		508-788-05	Slab reefing (with hooks)				536-119-01
		508-788-04	Single line reef (no hooks)	B120	Toggle (AL) Width: 20 Hole: Ø 10		
		508-788-06	Slab reefing (with hooks)				
	F176-F194 C137-C193	508-231-33	Furling mast	B120	Bracket Height: 160 Width: 61 Toggle (AL) Width: 20 Hole: Ø 12.5	12 pop rivets 167-002	536-113-01 Max. RM: Masthead 55 kNm Fractional 40 kNm
		508-231-34	Single line reef (no hooks)				
		508-231-35	Slab reefing (with hooks)				
	F212-F246 C211-C245	508-257-33	Furling mast	B120	Bracket Height: 174 Width: 71 Toggle (AL) Width: 20 Hole: Ø 12.5		
		508-257-34	Single line reef (no hooks)				
		508-257-35	Slab reefing (with hooks)				
	F176-F194 C156-C193	508-231-06	Furling mast	B135 143/76 B152	Bracket Height: 160 Width: 61 Toggle (AL) Width: 20 Hole: Ø 12.5		
		508-231-07	Single line reef (no hooks)				
		508-231-08	Slab reefing (with hooks)				
	F212-F246 C211-C245	508-257-03	Furling mast	B135 143/76 B152 B171 B172	Bracket Height: 174 Width: 71 Toggle (AL) Width: 20 Hole: Ø 12.5		
		508-257-04	Single line reef (no hooks)				
		508-257-05	Slab reefing (with hooks)				
	F265-F286 C265-C285	508-233-03	Furling mast	B171 B172	Bracket Height: 242 Width: 81 Toggle (ST) Width: 20 Hole: Ø 12.5	12 screws 155-622 (MRT 6 x 25, in backing plate)	Separate reef hooks: 507-651 Max. RM: Masthead 120 kNm Fractional 90 kNm
		508-233-04	Single line reef (no hooks)				
		508-233-05*	Slab reefing (with hooks)			12 screws 155-621 (MRT 6 x 20, in backing plate)	
	F228-F246	508-233-36	Furling mast	B199 B200	Bracket Height: 242 Width: 81 Toggle (ST) Width: 30 Hole: Ø 16.5	12 screws 155-622 (M6)	
	508-152-38*	Slab reefing (with hooks)					
		F265-F305 C264-C304	508-233-08	Furling mast	B199 B200 B250 B290 B300	Bracket Height: 242 Width: 81 Toggle (ST) Width: 30 Hole: Ø 16.5	
508-233-09			Single line reef (no hooks)				
508-233-06*			Slab reefing (with hooks)				

AL = Aluminium ST = Stainless steel * Masthead RM30° >120 kNm or Fractional RM30° >90 kNm, use "floating hooks".

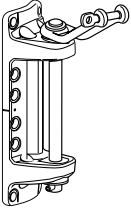

Boom brackets, Racing boom

Fitting	Mast section	Boom bracket Art. No.	Boom type	Boom section	Dimension, mm	Fasteners Art. No.	Separate pin, hooks Art. No.
	C175-C193	508-231-10	Slab reefing (with hooks)	B190 B230	Bracket Height: 160 Width: 71	12 screws 155-621 (MRT 6 x 20)	536-113-01 Max. RM: Masthead 55 kNm Fractional 40 kNm
		508-231-14	Single line reef (no hooks)	B190			
	C211-C245	508-257-07	Slab reefing (with hooks)	B190 B230	Bracket Height: 174 Width: 71		
		508-257-15	Single line reef (no hooks)				
							

Universal boom brackets

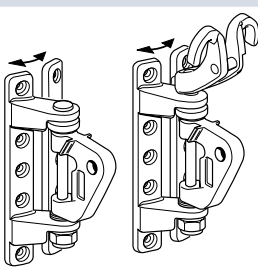
Fitting	Art. No.	Boom type	Boom section	Fasteners Art. No.
	508-237-05	Furling mast	B120	10 pop rivets 167-002 (Ø 6.4 x 17.8 MNL)
	508-237-08	Single line reef (no hooks)		
	508-237-11	Slab reefing (with hooks)		
	508-237-06	Furling mast	B135 143/76 B152 B171 B172	
	508-237-09	Single line reef (no hooks)		
	508-237-12	Slab reefing (with hooks)		
	508-237-07	Furling mast		
	508-237-10	Single line reef (no hooks)	B199 B200	
	508-237-13	Slab reefing (with hooks)		

These boom brackets are adjustable and fit most mast sections. Ideal when upgrading an old mast with a modern Seldén boom.

Reef line kits and sliders

Main sheet sliders

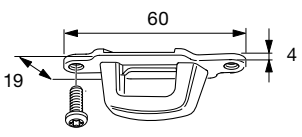
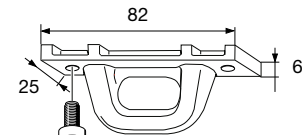
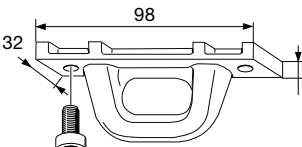
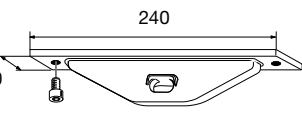
Fitting	Art. No.	Boom section
	511-641-01	B087 B104
	511-571-01	B120 B135 143/76 B152 B171 B172 B190*
	511-572-01	B199 B200 B230* B250
	511-616-01	B290 B300

* Webbing is often used as sheet attachment.

Single Line Reef kits

Boom section	Rope dia mm	Complete kit (reef 1 and 2 + outhaul) Art. No.	Excl. reef lines Art. No.
B120	8	611-007-10*	611-007-11
B135	10	611-011-14	611-011-15
B152	10	611-011-16	611-011-17
B171	10	611-011-12*	611-011-13
B171 (2008-)	10	611-011-24	611-011-25
/B172			
B200	12	611-015-04	-
B200 (2008-)	12	611-015-24	-
B250	12	611-015-25	-

Jam lever kits

Boom section	Art. No.
B135	511-074-21
143/76	511-072-11
B152	511-074-22
B153	511-278-10
B171	511-072-12 (-2007) 511-072-22 (2008-)
B172	511-280-10
B199	511-282-10
B200	511-071-11 (-2007) 511-071-21 (2008-)
B250	511-071-22

Lazyjack slider

Two part polyamide slider for Lazyjacks. Fits in the groove without removing the boom end.

For use with Lazyjacks and reef lines for loose footed sails only.

Fitting	Art. No.	Includes	B	Boom section
	511-636-01	One slider	18	B120-B172
	511-636-02	Two sliders with M6 screws (selftapping) and Ø 5.3 drillbit		
	511-637-01	One slider	25	B199- B290/300
	511-637-02	Two sliders with M6 screws (selftapping) and Ø 5.3 drillbit		



Retrofit outhaul track

This track can be retrofitted to an old boom and significantly improve the outhaul function.

A 400 mm long track with a ball bearing car is mounted in the sail track to simplify adjustment of the outhaul tension of a loose footed sail. A complete kit including track, traveller, end caps and fasteners (8 x 16 mm) for the sail track. Just remove the boom end, slide in the track and tighten the screws. Art. No. 511-580-11R. RCB22 / RM HM max.:40Nm / FRAC max.:30Nm 30°.



